

The MAP-300 incorporates a 4.3" capacitive touch vibrant display, internal relays, digital Inputs with assignable text, Modbus, milli-amp & RS485 detectors and is fully expandable.

Identify Alarm locations in an instant:

- User text to describe each device location.
- Dedicated area map.
- Connect up to 500 Devices.
- Calibrate via control panel for minimal intrusion.



System Features

- Remote calibration of detectors via control panel.
- Works with milli-amp and RS485 detectors or any device with a mA/Voltage output.
- Visual indication of gas levels
- 4.3" full colour TFT display
- Network up to 500 gas sensors
- U-processor based functionality
- RS 485 Modbus RTU
- Dedicated Customer 24v Supply
- 8 x Volt free contacts expandable to 96
- Alarm levels freely programmable
- Internal fault monitoring
- Dedicated Gas Valve Relay.

Gateway Modbus TCP / Modbus RTU/ASCII
Equipped with RJ45 Ethernet and www configuration website

Expansion:
64 mA In
64 mA Out
100 Relays



3x 24v Digital Inputs



8x 230Vac 10A Relays
Modbus RTU

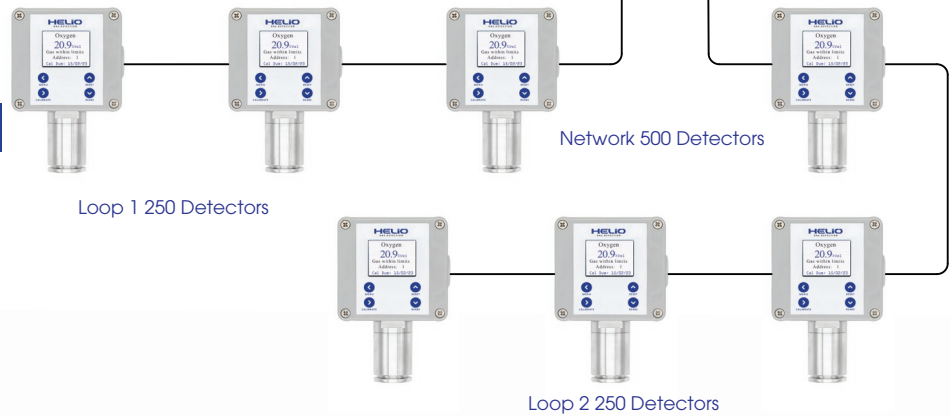

User Friendly

- Non-intrusive one person calibration
- Easy to use step by step menu
- Minimal training required
- Remotely calibrate detectors
- Programmable alarm delay
- Password protected
- Supplied pre-configured

Cost Benefits

- Supplied with dedicated 24v supply for customer use in supplying sounder/beacons etc.
- RS 485 network reduce cabling costs
- Simple installation
- Plug-in replacement sensors
- Detector stability allows for increased maintenance intervals



Environmental Specifications	
Operating temperature	-10 °C to 40 °C
Pressure range	80 to 120 kPa
Humidity range	15 to 90 % rh
Electrical Specifications	
Supply voltage	85Vac to 277Vac
Power Consumption	2W Panel Only
Fuse	3.15A Slow Blow, short circuit and overload protected.
Panel Specifications	
Detector Type	Milli-Amp & RS485
Relays	SPST 10A 230Vac x 4 expandable to 96
Annunciator output	n/a
Interface	4.3" Touch Screen Full Colour Display
Terminations	Plugable terminal blocks up to 2.5mm ² cores.
Alarm inhibit	Password protected alarm inhibit / muting
Alarm setting	Digital setting (fully adjustable between Zero and full scale)
Alarm types	De/Energised, Delayed, SPST Non-Latching / Latching
Resolution	0.01
Accuracy	Sensor dependent
Dimensions	252mm x 158mm x 90mm
Memory	64KB flash ROM
EN Regulation Compliance	EN50270, EN50271.

Electromagnetic conformance (EMC) complies with 2014/35/EU

Wiring Diagram

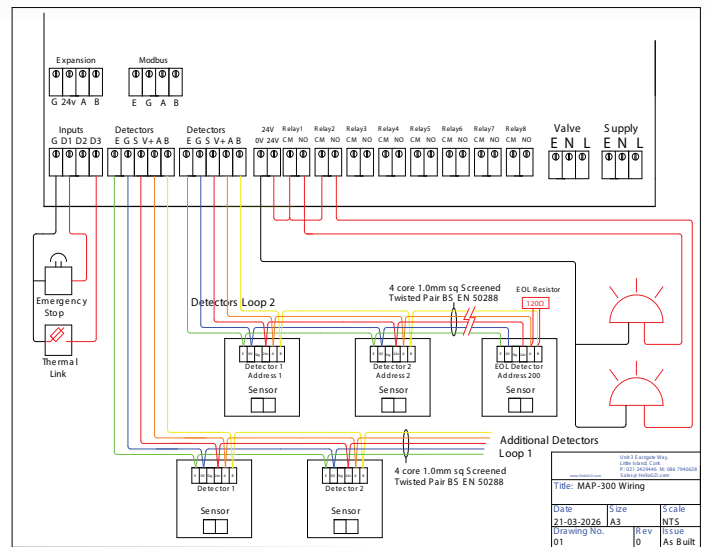

Dimensions (mm)

252mm x 158mm x 90mm



For more information:

T. +353 21 2429 448
E. sales@helioqd.com

www.HelioGD.com
Unit 3, Eastgate Way, Little Island, Cork, Ireland.

 [linkedin.com/company/helio-gas-detection](https://www.linkedin.com/company/helio-gas-detection)

