

The **SLEX detector** incorporates an LCD display, 4-20mA and RS485 communication which enables it to function as control panel and detector in one. The software provides control over all aspects of the detector

Applications include: Oil and Gas Industries, Waste Water Treatment, Pharma & Bio-Pharma, Manufacturing, Chemical and Fuel Storage Facilities



System Features

- EN 60079 II 2 G D Ex-d IIC T6
- Standalone gas detector
- Incorporates infra-red, electro-chemical, catalytic and PID sensor technologies
- Visual indication of gas levels
- LCD display
- Network up to 500 gas sensors
- U-processor based functionality
- RS 485 Interface
- 4-20mA output
- Internal fault monitoring
- Stainless steel sensor housing

User Friendly

- Non-intrusive one person calibration
- Easy to use step by step menu
- Minimal training required
- Remotely mount sensors
- Password protected
- Supplied pre-configured
- Supplied calibrated

Cost Benefits

- Standalone gas detector requiring no control panel
- RS 485 network reduce cabling costs
- Simple installation
- Plug-in replacement sensors
- Detector stability allows for increased maintenance intervals

STEL short term exposure limit 15minutes. **LTEL** long term exposure limit 8 hours.

IR - Infra-red, **EC** - Electrochemical, **CAT** - Catalytic

Gas	LTEL	STEL	%Vol LEL	Relative Density	Sensor
Air	-	-	-	1.000	
Ammonia	25 ppm	35 ppm	15%	0.597	EC
Arsine	-	0.05 ppm	4.50%	2.690	EC
Butane	750 ppm	600 ppm	1.86%	2.006	IR
Carbon Dioxide	5000 ppm	15000ppm	-	1.519	IR
Carbon Monoxide	30 ppm	200 ppm	12%	0.967	EC
Chlorine	-	0.5 ppm	-	2.486	EC
DMF	-	-	-	0.949	PID
Ethane	20 ppm	40 ppm	3%	1.038	IR/CAT
Ethanol	1000 ppm	-	3.30%	1.600	IR/CAT
Ethylene	-	-	2.75%	0.968	IR/CAT
Ethylene Oxide	5 ppm	-	3%	1.500	IR/CAT
Fluorine	1 ppm	1 ppm	-	1.310	EC
Hexane	20 ppm	-	1.25%	2.973	IR/CAT
Hydrogen	-	-	4%	0.070	CAT
Hydrogen Chloride	1 ppm	5 ppm	-	1.268	EC
Hydrogen Cyanide	-	10 ppm	5.60%	0.940	EC
Hydrogen Fluoride	1.8 ppm	3 ppm	-	0.700	EC
Hydrogen Sulphide	5 ppm	10 ppm	4%	1.176	EC
LPG	750 ppm	-	2.10%	1.8-2.1	IR/CAT
Methane (natural gas)	-	-	5%	0.5537 (0.6-0.7)	IR/CAT
Nitric Oxide	25 ppm	-	-	1.037	IR/EC
NMP	-	-	-	1.03	PID
Oxygen	-	-	-	1.104	EC
Ozone	-	0.2 ppm	-	1.660	EC
Pentane	600 ppm	-	1.40%	2.487	IR/CAT
Phosgene	0.02 ppm	0.06 ppm	-	1.390	EC
Phosphine	0.1 ppm	0.2 ppm	1.80%	1.170	EC/CAT
Propane	1000 ppm	-	2.10%	1.522	IR/CAT
Propylene	-	-	2%	1.452	IR/CAT
Sulphur Dioxide	2 ppm	5 ppm	-	2.264	EC
Tetrahydrothiophene	8 Hours	-	%Vol @ 20°C	Gas/Vapour	EC

Environmental Specifications

Operating temperature	-30 °C to 50 °C
Pressure range	80 to 120 kPA
Humidity range	15 to 90 % rh

Electrical Specifications

Supply voltage	24Vdc
Power Consumption	Max 2W
Fuse	50mA PTC short circuit and overload protected

Sensor Specifications

Combustible gas sensor type	NDIR, Thermo-catalytic
Toxic gas sensor type	NDIR, Electro-chemical
Transient protection	PCB mounted Metal Oxide varistor
Terminations	PCB terminal blocks up to 2.5mm ² cables
Alarm inhibit	Password protected alarm inhibit / muting
Resolution	1%
Accuracy	Sensor dependent
Full scale range	Freely programmable
Memory	64KB flash ROM
EN Regulation Compliance	EN45544-1-4 EN50194, EN501041, EN61779-1-5, EN60079-0,1
Electromagnetic conformance (EMC)	complies with EN50081 and EN50082

Wiring

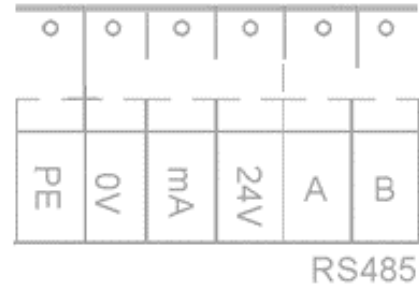

HELIO
GAS DETECTION

Dimensions (mm)

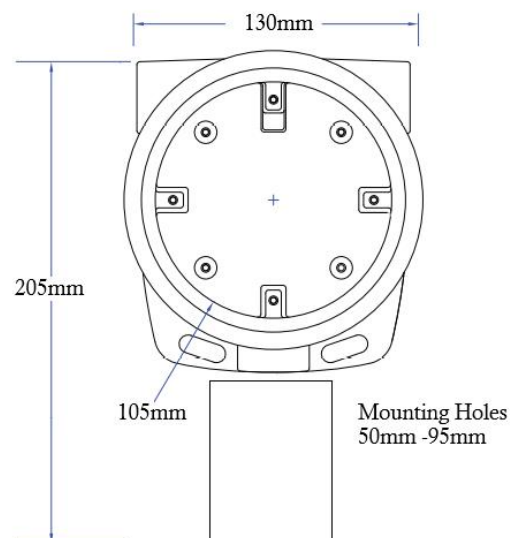
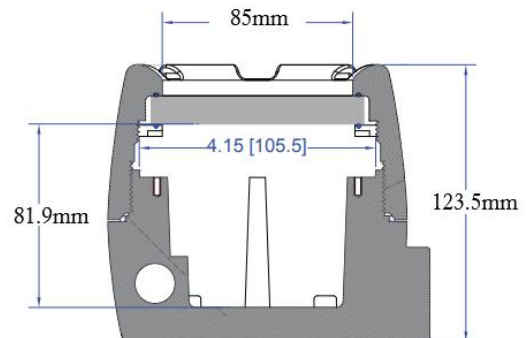

Find out more at www.helioGD.com

✉ info@helioGD.com

✉ sales@helioGD.com

00353 (0) 21 242 9448