

Identify exact locations of gas levels and alarms, get immediate information in an emergency situation



System Features

- Bespoke Graphic Displays
- 10" up to 75" Screens.
- View exact locations and readings in seconds
- Ideal for emergency response teams
- Allows multiple area displays with automatic or manual selection
- Numerous control panels can be connected to a single screen
- Directly connect detectors and control panels combined
- Wall or desktop mounted
- Remote dial-in viewing

User Friendly

- Touch screen interface.
- Easy to use Step by step menu.
- Customise displayed area floor plans.
- Supplied pre-configured.
- Minimal training required.
- Password protected.

Cost Benefits

- Connect up to 500 gas sensors as part of an RS 485 Network resulting in reduced cabling and installation costs.
- Simple installation allows the Graphics panel to be conveniently located.
- Compact unit 280mm x 320mm x 135mm.

STEL Short term exposure limit 15minutes. **LTEL** Long term exposure limit 8 hours.
IR - Infra-red, **EC** - Electrochemical, **CAT** - Catalytic

Gas	LTEL	STEL	%Vol LEL	Relative Density	Sensor
Air			-	1.000	
Ammonia	25 ppm	35 ppm	15%	0.597	EC
Arsine	-	0.05 ppm	4.50%	2.690	EC
Butane	750 ppm	600 ppm	1.86%	2.006	IR
Carbon Dioxide	5000 ppm	15000ppm	-	1.519	IR
Carbon Monoxide	30 ppm	200 ppm	12%	0.967	EC
Chlorine	-	0.5 ppm	-	2.486	EC
Chlorine Dioxide	0.1 ppm	0.3 ppm	3%	2.300	EC
Ethane	20 ppm	40 ppm	3%	1.038	IR/CAT
Ethanol	1000 ppm	-	3.30%	1.600	IR/CAT
Ethylene	-	-	2.75%	0.968	IR/CAT
Ethylene Oxide	5 ppm	-	3%	1.500	IR/CAT
Fluorine	1 ppm	1 ppm	-	1.310	EC
Hexane	20 ppm	-	1.25%	2.973	IR/CAT
Hydrogen	-	-	4%	0.070	CAT
Hydrogen Chloride	1 ppm	5 ppm	-	1.268	EC
Hydrogen Cyanide	-	10 ppm	5.60%	0.940	EC
Hydrogen Fluoride	1.8 ppm	3 ppm	-	0.700	EC
Hydrogen Sulphide	5 ppm	10 ppm	4%	1.176	EC
LPG	750 ppm	-	2.10%	1.8-2.1	IR/CAT
Methane (natural gas)	-	-	5%	0.5537 (0.6-0.7)	IR/CAT
Nitric Oxide	25 ppm	-	-	1.037	IR/EC
Nitrogen Dioxide	3 ppm	5 ppm	5%	1.590	EC
Oxygen	-	-	-	1.104	EC
Ozone	-	0.2 ppm	-	1.660	EC
Pentane	600 ppm	-	1.40%	2.487	IR/CAT
Phosgene	0.02 ppm	0.06 ppm	-	1.390	EC
Phosphine	0.1 ppm	0.2 ppm	1.80%	1.170	EC/CAT
Propane	1000 ppm		2.10%	1.522	IR/CAT
Propylene	-	-	2%	1.452	IR/CAT
Sulphur Dioxide	2 ppm	5 ppm	-	2.264	EC
Tetrahydrothiophene					EC
	8 Hours	15 Minutes	%Vol @ 20°C	Gas/ Vapour	

Environmental Specifications

Operating temperature	-10 °C to 60 °C
Storage Temperature	-20 °C to 70 °C
Humidity range	20 to 90 % non condensing

Electrical Specifications

Supply voltage	86Vac - 260Vac
Sensor cables	3 core, screened, 0.5mm ² to 2.5mm ²
Unit interrogation time	50mS – 2 Seconds

NOTE: Values are for a standard system there are numerous options available.

Dimensions (mm) (panel dependent)

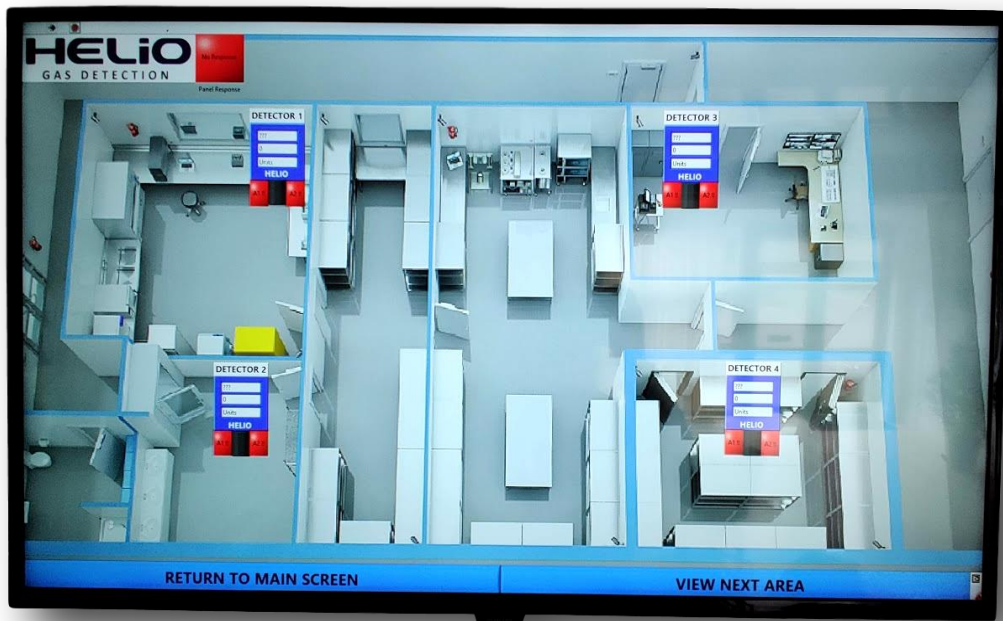
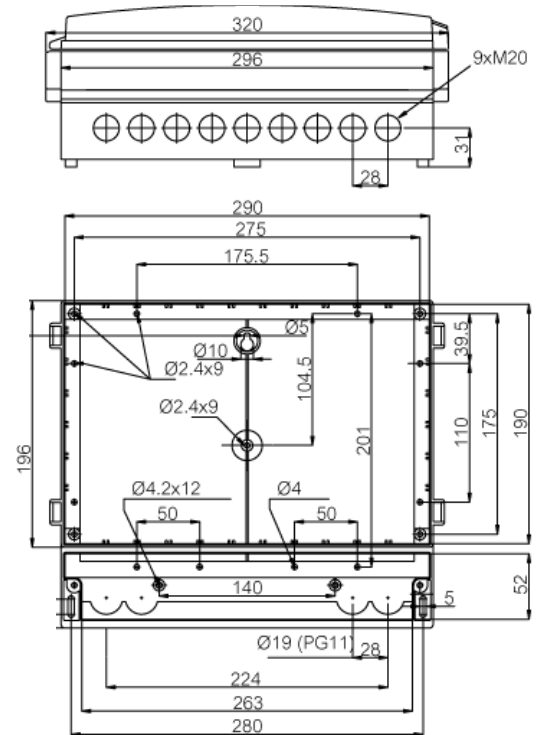

Find out more at www.helioGD.com

✉ sales@helioGD.com

00353 (0) 21 242 9448