

The **DTEX detector** incorporates a vibrant display, internal relays and RS485 communication which enables it to function as control panel and detector in one. The software provides control over all aspects of the detector

Applications include: Oil and Gas Industries, Waste Water Treatment, Pharma & Bio-Pharma, Manufacturing, Chemical and Fuel Storage Facilities



System Features

- EN 60079 II 2 G D Ex-d IIC T6
- Standalone gas detector
- Incorporates infra-red, electro-chemical, catalytic and PID sensor technologies
- Visual indication of gas levels
- 1.7" full colour TFT display
- Network up to 500 gas sensors
- U-processor based functionality
- RS 485 Modbus RTU
- 4-20mA outputs
- 3 x Volt free contacts
- Alarm levels freely programmable
- Internal fault monitoring
- Stainless steel sensor housing

User Friendly

- Non-intrusive one person calibration
- Easy to use step by step menu
- Minimal training required
- Remotely mount sensors
- Programmable alarm delay
- Password protected
- Supplied pre-configured

Cost Benefits

- Standalone gas detector requiring no control panel
- RS 485 network reduce cabling costs
- Simple installation
- Plug-in replacement sensors
- Detector stability allows for increased maintenance intervals

STEL short term exposure limit 15minutes. **LTEL** long term exposure limit 8 hours.
IR - Infra-red, **EC** - Electrochemical, **CAT** - Catalytic

Gas	LTEL	STEL	%Vol LEL	Relative Density	Sensor
Air	-	-	-	1.000	
Ammonia	25 ppm	35 ppm	15%	0.597	EC
Arsine	-	0.05 ppm	4.50%	2.690	EC
Butane	750 ppm	600 ppm	1.86%	2.006	IR
Carbon Dioxide	5000 ppm	15000ppm	-	1.519	IR
Carbon Monoxide	30 ppm	200 ppm	12%	0.967	EC
Chlorine	-	0.5 ppm	-	2.486	EC
DMF	-	-	-	0.949	PID
Ethane	20 ppm	40 ppm	3%	1.038	IR/CAT
Ethanol	1000 ppm	-	3.30%	1.600	IR/CAT
Ethylene	-	-	2.75%	0.968	IR/CAT
Ethylene Oxide	5 ppm	-	3%	1.500	IR/CAT
Fluorine	1 ppm	1 ppm	-	1.310	EC
Hexane	20 ppm	-	1.25%	2.973	IR/CAT
Hydrogen	-	-	4%	0.070	CAT
Hydrogen Chloride	1 ppm	5 ppm	-	1.268	EC
Hydrogen Cyanide	-	10 ppm	5.60%	0.940	EC
Hydrogen Fluoride	1.8 ppm	3 ppm	-	0.700	EC
Hydrogen Sulphide	5 ppm	10 ppm	4%	1.176	EC
LPG	750 ppm	-	2.10%	1.8-2.1	IR/CAT
Methane (natural gas)	-	-	5%	0.5537 (0.6-0.7)	IR/CAT
Nitric Oxide	25 ppm	-	-	1.037	IR/EC
NMP	-	-	-	1.03	PID
Oxygen	-	-	-	1.104	EC
Ozone	-	0.2 ppm	-	1.660	EC
Pentane	600 ppm	-	1.40%	2.487	IR/CAT
Phosgene	0.02 ppm	0.06 ppm	-	1.390	EC
Phosphine	0.1 ppm	0.2 ppm	1.80%	1.170	EC/CAT
Propane	1000 ppm	-	2.10%	1.522	IR/CAT
Propylene	-	-	2%	1.452	IR/CAT
Sulphur Dioxide	2 ppm	5 ppm	-	2.264	EC
Tetrahydrothiophene	8 Hours	-	%Vol @ 20°C	Gas/ Vapour	EC

Environmental Specifications

Operating temperature	-30 °C to 50 °C
Pressure range	80 to 120 kPA
Humidity range	15 to 90 % rh

Electrical Specifications

Supply voltage	24Vdc
Power Consumption	Max 2W
Fuse	100mA'T' short circuit and overload protected

Sensor Specifications

Combustible gas sensor type	NDIR, Thermo-catalytic
Toxic gas sensor type	NDIR, Electro-chemical
Annunciator output	>80dB (A) @1m
Transient protection	PCB mounted Metal Oxide varistor
Terminations	PCB terminal blocks up to 1.5mm ² cables
Alarm inhibit	Password protected alarm inhibit / muting
Alarm setting	Digital setting (fully adjustable between 10% and 90% of full scale)
Alarm types	Energised / de-energised Enrichment / deficiency
Resolution	1%
Accuracy	Sensor dependent
Full scale range	Freely programmable
Memory	64KB flash ROM
EN Regulation Compliance	EN45544-1-4 EN50194, EN501041, EN61779-1-5, EN60079-0,1
Electromagnetic conformance (EMC)	complies with EN50081 and EN50082



Wiring

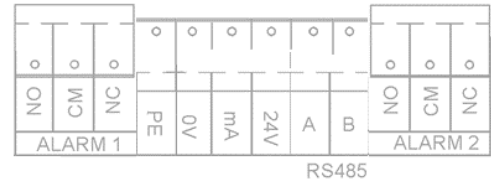

HELIO
GAS DETECTION

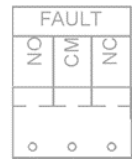

Dimensions (mm)

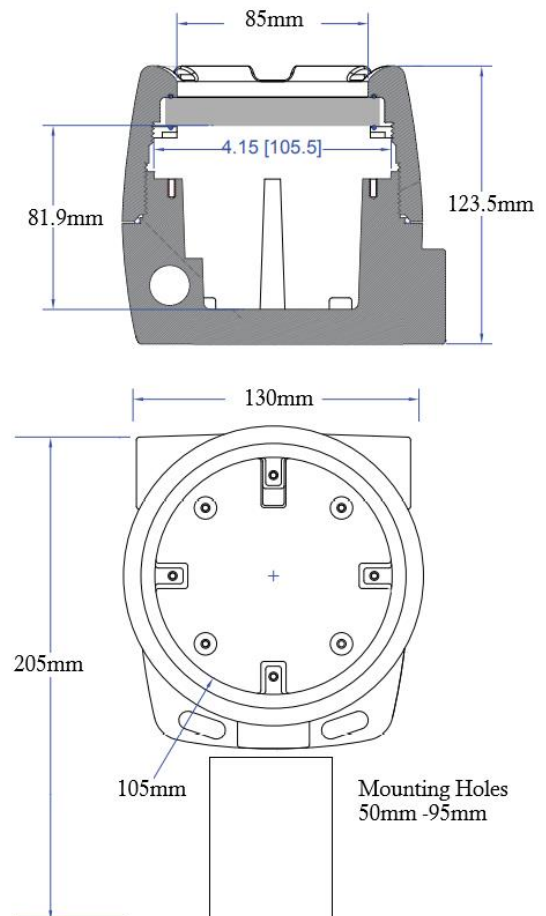

Find out more at www.helioGD.com

✉ info@helioGD.com

✉ sales@helioGD.com

00353 (0) 21 242 9448