

## Applications include:

Waste Water Treatment Facilities,  
Manufacturing, Pharma, Bio-Pharma,  
Food and Beverage industries,  
Boilers, Laboratories, Car parks,  
Agriculture, and Landfill sites.



## System Features

- Remotely mount up to 4 gas sensors.
- Incorporates Infra-red, Electro-chemical, Catalytic and PID sensor technologies.
- 4-20mA Inputs accepted.
- Visual indication of gas levels.
- 3.2" Full Colour display.
- Can be part of MAP network.
- u-Processor based functionality.
- RS 485 Communication.
- 4 x 4-20mA outputs.
- 9 x Volt free contacts. 5A @ 230Vac
- Alarm levels freely programmable.
- Internal fault monitoring.

## User Friendly

- Non intrusive one person calibration.
- Easy to use Step by step menu.
- Minimal training required.
- Remotely mount sensors.
- Programmable alarm delay.
- Password protected.
- Supplied pre-configured.

## Cost Benefits

- Aluminium Enclosure
- RS 485 Network reduce cabling costs.
- Simple installation.
- Plug-in replacement sensors.
- Detector stability allows for increased maintenance intervals.

**STEL** Short term exposure limit 15minutes. **LTEL** Long term exposure limit 8 hours.  
**IR** - Infra-red, **EC** - Electrochemical, **CAT** - Catalytic

Gas	LTEL	STEL	%Vol LEL	Relative Density	Sensor
Air			-	1.000	
Ammonia	25 ppm	35 ppm	15%	0.597	EC
Arsine	-	0.05 ppm	4.50%	2.690	EC
Butane	750 ppm	600 ppm	1.86%	2.006	IR
Carbon Dioxide	5000 ppm	15000ppm	-	1.519	IR
Carbon Monoxide	30 ppm	200 ppm	12%	0.967	EC
Chlorine	-	0.5 ppm	-	2.486	EC
Chlorine Dioxide	0.1 ppm	0.3 ppm	3%	2.300	EC
Ethane	20 ppm	40 ppm	3%	1.038	IR/CAT
Ethanol	1000 ppm	-	3.30%	1.600	IR/CAT
Ethylene	-	-	2.75%	0.968	IR/CAT
Ethylene Oxide	5 ppm	-	3%	1.500	IR/CAT
Fluorine	1 ppm	1 ppm	-	1.310	EC
Hexane	20 ppm	-	1.25%	2.973	IR/CAT
Hydrogen	-	-	4%	0.070	CAT
Hydrogen Chloride	1 ppm	5 ppm	-	1.268	EC
Hydrogen Cyanide	-	10 ppm	5.60%	0.940	EC
Hydrogen Fluoride	1.8 ppm	3 ppm	-	0.700	EC
Hydrogen Sulphide	5 ppm	10 ppm	4%	1.176	EC
LPG	750 ppm	-	2.10%	1.8-2.1	IR/CAT
Methane (nat gas)	-	-	5%	0.5537 (0.6-0.7)	IR/CAT
Nitric Oxide	25 ppm	-	-	1.037	IR/EC
Nitrogen Dioxide	3 ppm	5 ppm	5%	1.590	EC
Oxygen	-	-	-	1.104	EC
Ozone	-	0.2 ppm	-	1.660	EC
Pentane	600 ppm	-	1.40%	2.487	IR/CAT
Phosgene	0.02 ppm	0.06 ppm	-	1.390	EC
Phosphine	0.1 ppm	0.2 ppm	1.80%	1.170	EC/CAT
Propane	1000 ppm		2.10%	1.522	IR/CAT
Propylene	-	-	2%	1.452	IR/CAT
Sulphur Dioxide	2 ppm	5 ppm	-	2.264	EC
Tetrahydrothiophene					EC
	8 Hours		%Vol @ 20°C	Gas / Vapour	

## Environmental Specifications

Operating temperature	-30 °C to 50 °C
Pressure range	80 to 120 kPa
Humidity range	15 to 90 % rh

## Electrical Specifications

Supply voltage	24Vdc (230Vac Option)
Power Consumption	Max 4W
Fuse	400mA PTC and overload protected

## Sensor Specifications

Combustible gas sensor type	NDIR, Thermo-catalytic
Toxic gas sensor type	NDIR, Electro-chemical
Annunciator output	>80dB (A) @1m
Transient protection	PCB mounted Metal Oxide Varistor
Terminations	PCB terminal blocks up to 1.5mm2 cables
Alarm inhibit	Password protected alarm inhibit / muting
Alarm setting	Digital setting (fully adjustable between 1% and 99% of full scale)
Alarm types	Energised / De-energised. Enrichment / Deficiency
Resolution	1%
Accuracy	Sensor dependent
Full scale range	Freely programmable
Memory	64KB Flash

Electromagnetic Conformance(EMC) Compiles with EN50081 and EN50082

## Wiring

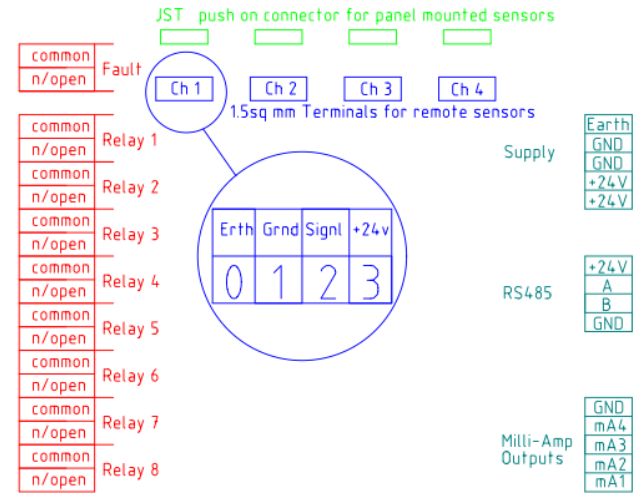

## Dimensions (mm)

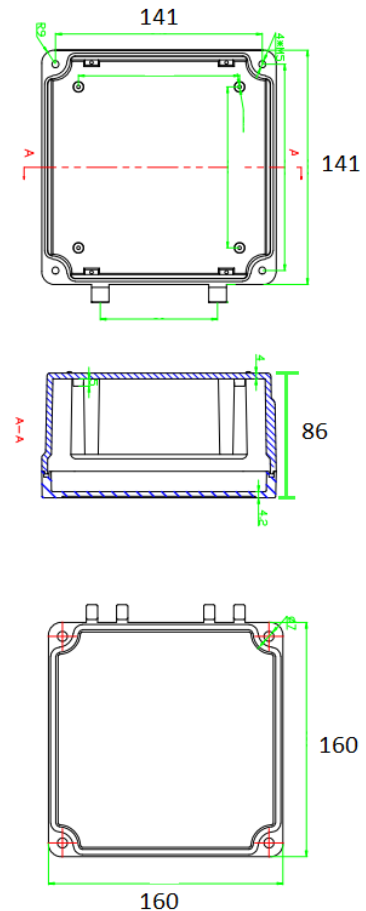

Find out more at [www.helioGD.com](http://www.helioGD.com)

✉ [info@heliogd.com](mailto:info@heliogd.com)

✉ [sales@heliogd.com](mailto:sales@heliogd.com)

00353 (0) 21 242 9448