

H-400 PORTABLE GAS DETECTOR

The **H-400 PORTABLE detector** incorporates a vibrant display, Vibration, Buzzer and LED Alerts.

Applications include: Waste Water Treatment Facilities, Manufacturing, Pharma, Bio-Pharma, Food and Beverage industries, Boilers, Laboratories, Car parks, Agriculture and Landfill sites.



System Features

- 4/5 gases detected
- EN 60079 II 3G Ex-ia IIC T6
- Incorporates Infra-red, electro-chemical, catalytic and PID sensor technologies
- Visual indication of gas levels
- 1.8" LCD display
- No additional software required.
- μ processor based functionality
- Backlight display
- Rear fastening clip.
- Micro USD charging.
- Alarm levels freely programmable
- Internal fault monitoring
- Calibration kit included

User Friendly

- Non-intrusive one person calibration
- Easy to use step by step menu
- Minimal training required
- Standard phone charger
- Single screw calibration cup
- Supplied pre-configured

Cost Benefits

- One of the most cost-effective detectors available.
- Simple operation
- Plug-in replacement sensors
- Detector stability allows for increased Maintenance intervals

STEL short term exposure limit 15minutes. **LTEL** long term exposure limit 8 hours.
IR - Infra-red, **EC** - Electrochemical, **CAT** - Catalytic

Gas	LTEL	STEL	%Vol LEL	Relative Density	Sensor
Air	-	-	-	1.000	
Ammonia	25 ppm	35 ppm	15%	0.597	EC
Arsine	-	0.05 ppm	4.50%	2.690	EC
Butane	750 ppm	600 ppm	1.86%	2.006	IR
Carbon Dioxide	5000 ppm	15000ppm	-	1.519	IR
Carbon Monoxide	30 ppm	200 ppm	12%	0.967	EC
Chlorine	-	0.5 ppm	-	2.486	EC
Chlorine Dioxide	0.1 ppm	0.3 ppm	3%	2.300	EC
Ethane	20 ppm	40 ppm	3%	1.038	IR/CAT
Ethanol	1000 ppm	-	3.30%	1.600	IR/CAT
Ethylene	-	-	2.75%	0.968	IR/CAT
Ethylene Oxide	5 ppm	-	3%	1.500	IR/CAT
Fluorine	1 ppm	1 ppm	-	1.310	EC
Hexane	20 ppm	-	1.25%	2.973	IR/CAT
Hydrogen	-	-	4%	0.070	CAT/EC
Hydrogen Chloride	1 ppm	5 ppm	-	1.268	EC
Hydrogen Cyanide	-	10 ppm	5.60%	0.940	EC
Hydrogen Fluoride	1.8 ppm	3 ppm	-	0.700	EC
Hydrogen Sulphide	5 ppm	10 ppm	4%	1.176	EC
LPG	750 ppm	-	2.10%	1.8-2.1	IR/CAT
Methane (natural gas)	-	-	5%	0.5537 (0.6-0.7)	IR/CAT
Nitric Oxide	25 ppm	-	-	1.037	IR/EC
Nitrogen Dioxide	3 ppm	5 ppm	5%	1.590	EC
Oxygen	-	-	-	1.104	EC
Ozone	-	0.2 ppm	-	1.660	EC
Pentane	600 ppm	-	1.40%	2.487	IR/CAT
Phosgene	0.02 ppm	0.06 ppm	-	1.390	EC
Phosphine	0.1 ppm	0.2 ppm	1.80%	1.170	EC/CAT
Propane	1000 ppm	-	2.10%	1.522	IR/CAT
Propylene	-	-	2%	1.452	IR/CAT
Sulphur Dioxide	2 ppm	5 ppm	-	2.264	EC
Tetrahydrothiophene	8 Hours	-	%Vol @ 20°C	Gas/Vapour	EC

Environmental Specifications

Operating temperature	-10 °C to 50 °C
Pressure range	80 to 120 kPA
Humidity range	15 to 90 % rh

Electrical Specifications

Supply voltage	3.7Vdc
Power Consumption	Max 0.2W

Sensor Specifications

Sensor types	NDIR, Thermo-catalytic, Electro-chemical, PID
--------------	---

Annunciator output	>80dB (A) @1m
Transient protection	PCB mounted Metal Oxide varistor

Alarm level	Freely programmable
-------------	---------------------

Alarm Hysteresis	Reset level freely programmable
------------------	---------------------------------

Alarm types indication	STEL TWA Visual
------------------------	-----------------

Resolution	0.1 & 1
------------	---------

Accuracy	Sensor dependent
----------	------------------

Memory	64KB flash ROM
--------	----------------

EN Regulation Compliance	EN45544-1-4 EN50194, EN501041, EN61779-1-5, IEC61508
--------------------------	--

Kit



Dimensions (mm)

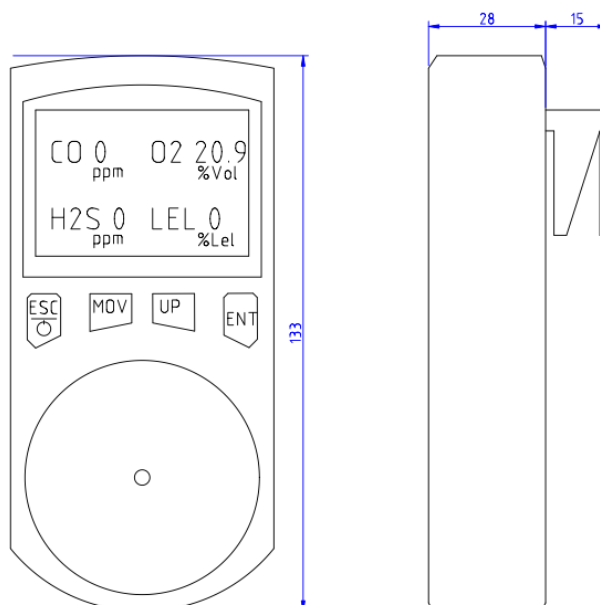

Find out more at www.helioGD.com

✉ info@heliogd.com

✉ sales@heliogd.com

00353 (0) 21 242 9448